



Builder, Subcontractor or Supplier:

Please forward these instructions to the homeowner.

The application performance standards for these products may be governed by the International Residential Code, International Building Code and other state and jurisdictional requirements. Copies of performance ratings are available on our website at www.thermatru.com.

Installation Instructions for Pre-hung Door Systems

These installation instructions are designed to assist door installers who have an understanding of carpentry principles, and know how to properly and safely use power tools. The purpose of these instructions is to illustrate how to install a Therma-Tru door system using methods and materials that help eliminate water related leaks. If the directions are closely followed, the door system will have a long useful life with good resistance to rain related water intrusion problems.

These methods are "tried and true" They are used widely by builders and remodelers who are serious about managing and keeping water outside the home. Rather than eliminate any steps that may be unclear to you, please call 1-800-THERMA-TRU and ask for clarification. If you remain unclear, please seek more professional assistance with the installation.

Different parts of the country have different code requirements, which may not be covered in these instructions. The installer is responsible for insuring the installation complies with local codes. If you have unique code requirements that do not appear please contact 1-800-THERMA-TRU.

If disturbing existing paint, take proper precautions if lead paint is suspected (commonly used before 1979). For information regarding lead paint regulations, refer to www.epa.gov/lead.

For products being removed, always ensure that these products are properly disposed of or recycled in accordance with local jurisdictional requirements.

Required Tools & Materials: Tape measure, 6-foot and 2-foot level, framing square, at least 20 feet of string or twine and push pins, several tubes of high-quality hybrid polymer, elastomeric or polyurethane sealant (Therma-Tru recommends OSI QUAD MAX sealant for its adhesion strength and long-term durability across various building materials applications), caulking gun, step ladder, small pry bar, hammer, safety glasses, gloves, utility knife, punch or brad nailer, tin snips, electric drill or screw gun, two screw drivers (one Phillips and one flat-blade), composite or cedar shims, putty knives, one stiff, one flexible, exterior grade number 8 x 2-1/2" screws, self-adhesive flashing tape, j-roller, rigid head flashing, closed cell low expansion polyurethane window and door foam (Therma-Tru recommends OSI QUAD FOAM because it surpasses our requirements and is available with a professional application gun, allowing multiple uses from one can of foam), proper foam application gun, foam cleaner and a rigid Therma-Tru sill pan. Exterior trim if needed.

Additional products may be required depending on your local building codes, so be sure to check with your building department and follow their guidelines

Read all instructions before starting.



Therma-Tru Recommended Best Practices

Use Water Resistive Barrier and Flexible Flashing:
We recommend the use of a Water Resistive Barrier (WRB) applied to the exterior sheathing (OSB or other) and the use of an adhesive or flexible flashing product to seal around the opening. The WRB should be cut in the opening (follow manufacturer's guidelines) with the head of the flap taped up, to be sealed later in Step 11. The flashing should be applied in an overlapping manner as shown, always working from the bottom up (follow manufacturer's guidelines).

Use a Sill Pan: We recommend you first "dry fit" the sill pan in the opening, following the instructions furnished with the sill pan. Place the right and left sill pan ends tight against the sides of the opening. Check the center section for proper length and if necessary, cut with a hack saw or tin snips. Be sure to allow 2 inches of overlap at the joints.

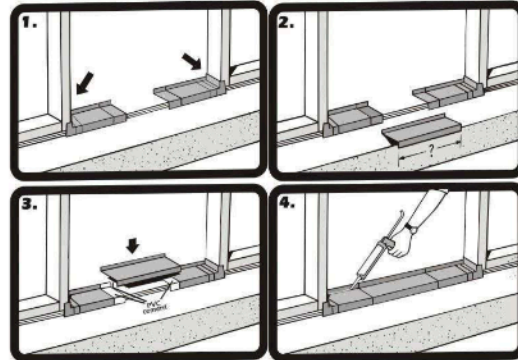

Note: Use only the PVC cement provided in the sill pan kit to glue the pieces together. The sill pan must be sealed to the sub-floor using a high-quality hybrid polymer, elastomeric or polyurethane sealant; Therma-Tru recommends OSI QUAD MAX, but do not apply sealant to the bottom of the sill when using a sill pan.

Step 1: Check Door Unit.

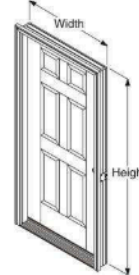

Check width and height.
Measure size of frame (width and height), not brickmould.
Remove cleats and packaging, but keep door fastened closed with transport clip. Do Not remove the transport clip until instructed to do so later in Step 7.

Step 2: Check and Prepare Opening.

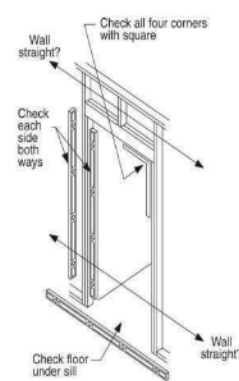

Is the opening the correct size for the door unit? Check it against the door frame size now, before installation. The opening should be frame height plus 1/2 inch, and frame width plus 1/2 inch to 3/4 inch.

Fix any problems now.

Are the framing and walls **PLUMB**? Use a 6 foot level and check both sides of the opening, both ways (front to back and right to left).

Fix any problems now.

Is the sub floor level and solid? **Provide a flat, level, clean weight bearing surface so the sill pan or sill can be properly caulked and sealed to the opening. Scrape sand or fill as required.**

Note: If additional floor covering clearance is required, attach the shim board to the sub floor. Be sure to caulk well under the shim board.

Is the opening square? Check all corners with a framing square. Double check by comparing diagonal measurements.
Fix any problems now.



Pre-Hung Unit Installation

Step 2 cont.: Check and Prepare Opening.

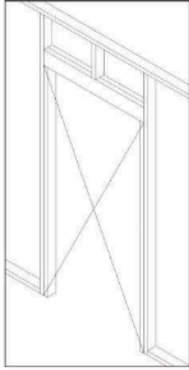

Check to be sure the framing walls around the opening are in the same plane. Do this by performing a "string test" for plumb.

String Test for Plumb: Attach a string diagonally across the opening from the outside, as shown. The string(s) should gently touch in the center, if not the opening is "out of plumb" by twice that distance and needs to be corrected. Flip the string over itself to check both planes. **Fix any problems now.**

*An "out of plumb" condition is one of the most common reasons door units leak air and water.

Step 3: Caulk the Sub Floor.

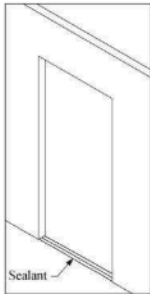

On the sub floor at opening, place 3 very large beads of sealant. Run beads full width of the opening.

Use Only a high-quality hybrid polymer, elastomeric or polyurethane sealant; Therma-Tru recommends OSI QUAD MAX.

Use an Entire Tube when Caulking along the Sub Floor.

Step 3A: Installation with a Sill Pan.

Place the right and left sill pan ends onto the caulk beads and tightly against the side of the opening.

Then, liberally coat the overlapped areas and the recessed areas of the pieces with the PVC cement provided. Place center section(s) in position and hold pieces together long enough to ensure a good bond.

For added protection, spread a bead of caulk along the glue joints and to prevent air infiltration, run a bead of caulk along the lower interior edge of the sill pan. Additional caulking could affect the performance of the sill pan.

Do Not Caulk the bottom of the Sill when using a sill Pan.

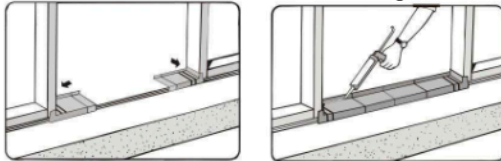

Step 3B: Installation without a Sill Pan.

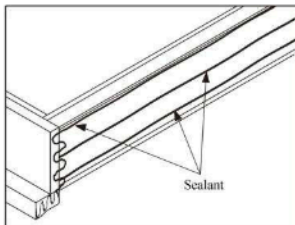

Lay the door unit on edge or face so that the bottom surface of the sill can be caulked. Place very large beads of caulk across the full width of the sill. Additionally, place beads of caulk along the junction of the sill and the jamb and on the bottom surface of the jambs and brickmould.

Note: If a sill extender is used, place a large bead of caulk at the junction of the extender and the sill approach.

Step 3C: Caulking Back side of Brickmould.

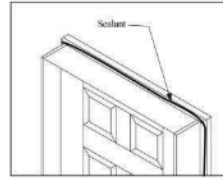

Important!

Apply sealant to the back side of brickmould around the entire perimeter of the door unit. A 1/2 – 5/8 inch bead of a high-quality hybrid polymer, elastomeric or polyurethane sealant is essential. Therma-Tru recommends OSI QUAD MAX.

Step 4: Place Unit in Opening, Temporarily Fasten, And Plumb Hinge Side Jamb.

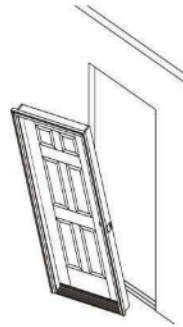

Lift the unit up. With top edge tilted away from opening, center the unit and place sill down onto sill pan or caulk beads and tilt into opening.

For all door unit configurations, note the hinge locations and mark those locations on the jamb faces near the door surfaces. Pre-drill 1/8 inch diameter holes at these locations for screw placement. For Therma-Tru Composite Door Frame systems, also pre-drill 1/8 inch diameter holes between hinge locations on both jambs. A counter sink bit will help to conceal the screw heads, if not using provided hidden fastening system.

Install screws in the center pre-drilled hole locations on both jambs to temporarily secure the unit in the place. Do not drive screws completely in at this time. Use #8 X 2-1/2 inch or 3 inch exterior grade screws. If installing with provided hidden fastening system, install with provided screws.

Do Not Fasten through the Brickmould.

Work from side of the door that is weather-stripped. Use a 6 foot level and plumb the hinge side jamb both ways (right to left and inside to outside).

Place screws through the hinge side jamb into the studs, at each hinge location, as shown in the diagrams. For Therma-Tru Composite Door Frame systems, also place screws between hinge locations as shown in the diagrams. Use #8 X 2-1/2 inch or 3 inch exterior grade screws. If installing with provided hidden fastening system, install with provided screws.

Do Not, drive the screws completely in at this time.

For Single or Double Doors, place screws at each location, so shims can be placed above screws. The screws will keep the shims from falling down while adjustments are being made.

For Double Door and Patio Units, fasten fixed or passive side of the unit first.

For Sidelite units, fasten the jamb on the hinge side of the door first.

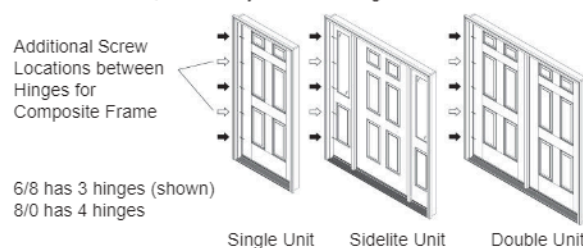

Step 5: Shim at Hinge Locations and Secure Hinge Jamb.



Leave door fastened and closed with transport clip.

Shim above X screws, behind each hinge location, between the opening and the jamb.

Use a 6 foot level and re-check hinge jamb to ensure it is **plumb** and straight.

Finish driving screws tight in the middle first then top and bottom last.

Step 6: Adjust Rest of Frame and Fasten.

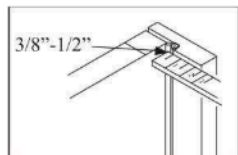

From the weatherstrip side of the door, check weatherstrip margins and contact.

Make frame adjustments so the weatherstrip contacts the door surface equally at the top, middle and bottom, an even 3/8 inch to 1/2 inch when fully closed.

Secure the lock side jamb with #8 X 2-1/2 or 3 inch screws through the pre-drilled holes at the top and bottom. **Do Not** drive screws tight at this time.

From the swing side of the door, shim above the screw locations and make adjustments so the margins between the door and frame are even top to bottom.

Note: For Double Doors, make adjustments that effect the alignment, margins and weatherstrip contact between the doors. Also follow the Astragal Site Package Instructions for details on properly setting the slide bolt hole locations.



Re-check everywhere for plumb and square, and an even weatherstrip contact.

Finish driving all screws tight.

Step 7: Remove Transport Clip and Open Door.

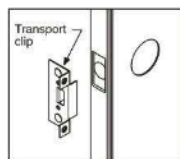

Remove the transport clip.

Open and close door to check for smooth operation.

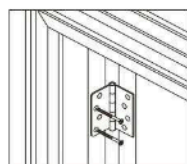

With the door open, drill 1/8 inch diameter pilot holes in the screw hole locations closest to the weather strip that were intentionally left blank. For the top hinge, if the holes are not left blank, remove the two screws closest to the weather strip. Then, install the #10 X 2-1/2 inch screws (provided) through the hinge, into the stud, to anchor the door frame and prevent sagging.

For Sidelite and Patio Units: With the door open, check to determine if the 2-1/2 inch long hinge screws were pre-installed in the hinges. If not, drill 1/8 inch diameter pilot holes and install the long hinge screws in the hole locations closest to the weatherstrip.

Close the door and carefully shim between the jamb and the opening behind the adjustable strike plate area.

Then open the door and drill 1/8 inch dia. pilot holes and install the #8 X 2-1/2 inch screws (provided) through the strike plate holes to secure the lock side jamb and provide security.

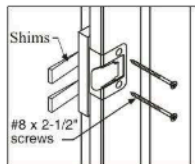

Adjust strike plate in or out for proper weatherstrip contact and door operation, then finish tightening screws.

Step 8: Adjust Sill.

Your door unit may have an adjustable threshold cap. When properly adjusted, it should be snug and slightly difficult to pull a dollar bill out from under the door when it is fully closed. The dollar bill should be able to be removed without tearing.

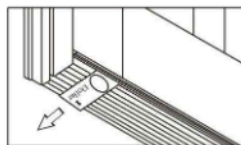

This check should be performed at each adjustment screw location.

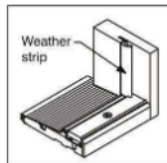

After adjusting the threshold cap, ensure that the weatherstrip is **flush** with the top of the threshold cap. Trim as necessary.

Step 9: Install Corner Seal Pads – Inswing units Only.

Apply sealant (a high-quality hybrid polymer, elastomeric or polyurethane sealant; Therma-Tru recommends OSI QUAD MAX.) at the joint where the threshold cap meets the door jambs.

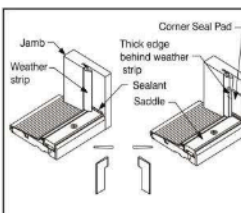

Remove the self-stick paper from the corner seal pads and apply to the door jamb, with the **bottom** lined up evenly with the top of the threshold cap. When the pad is correctly installed, the tab is on top and the narrow part is on the bottom.

The bottom of the pad is the same width of the threshold cap to help with alignment during installation.

Step 10: Additional Frame Anchoring.

If sill is prepared for anchoring screws, place appropriate screws through the sill into the sub floor where needed. (Primarily on Outswing Sills)

We recommend that you provide additional frame anchoring as shown here. Certain states or jurisdictions, notably Florida and the coast of Texas, have specific installation requirements and may require installation in strict accordance with the product approval for a specific product. You should always check with the local authority having jurisdiction for any specific installation requirements that may apply. Specific product approval installation instructions, including those required for the High Velocity Zone (HVHZ), are also available at www.thermatru.com

Pre-Hung Unit Installation

Step 10 cont.: Additional Frame Anchoring.

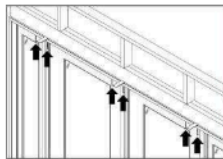

For units with Mull Post (s):

Shim above mull post (s), Pre-drill and insert a screw through the frame into the header, on each side of the mull post (s). If installing with provided hidden fastening system, install with provided screws.

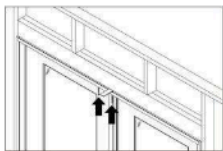

For Double Doors:

Place temporary shims above the center of the head frame, where doors meet. Insert screws into the strike plate and into the header, then remove the temporary shims. If installing with provided hidden fastening system, install with provided screws.

Step 11: Weatherproof, Finish and Maintain.



Provide and maintain a properly installed cap or head flashing to protect top of surfaces from **Water intrusion** and damage. Tape and properly seal the top flap of the Water Resistive Barrier (WRB) over the head flashing.

Caulk around **entire** "weather" side of unit, sealing along the brickmould to the flashing material or siding and seal all joints between the jambs and moldings.

Seal the joints between the exterior hardware trim and the door face to **prevent** air and water infiltration.

Place and set galvanized finish nails through the brickmould around the perimeter. Use exterior grade screws if you are installing a storm door to the brickmould. Countersink all fasteners and cover with exterior grade putty.

Use a low expansion window and door foam in the cavity between the opening and unit to reduce **air & water infiltration** and **heat transfer**. Therma-Tru recommends OSI QUAD FOAM.

All Therma-Tru Steel doors must be finished within several days of the installation date for continued warranty coverage. For Fiberglass doors the finishing requirement is within 6 months of installation.

Paint or stain according to Therma Tru Finishing instructions. Do Not paint or stain the weatherstrip, it is "friction-fit" and easily removed for painting or staining.

All 6 sides of the doors must be finished. For out-swing doors the sides, top and bottom must be inspected and maintained as regularly as all other surfaces.

All bare wood surfaces such as the door frame exposed to weather should be primed and painted or stained and top coated **within** two weeks of exposure for best performance.

Maintain or replace sealants and finishes as soon as any deterioration is evident. For semi-gloss or glossy paint or clear coats, do this when the surface becomes dull or rough. More severe climates and exposures will require more frequent maintenance.

Access our website www.thermatru.com for printable versions of the installation and Same Day Stain finishing instructions and to view our Troubleshooting video for minor installation issues and adjustments.

Finishing Instructions.

Work only when temperatures are between 50° and 90°F and with humidity less than 85%. Do not finish in direct sunlight.

Steel and Smooth-Star® Doors:

To paint Doors: Clean first with mild detergent and water or use a TSP (tri-sodium phosphate) solution. Rinse well and allow to dry completely. Mask off hardware, glass and remove weatherstripping before painting. Use high-quality acrylic latex house paint, following manufacturer's directions for application. Use exterior grade finishes for outside surfaces. Paint edges and exposed ends of door.

To Paint Doorlite Frames:

Remove any excess glass glazing sealant by first spraying with a window cleaner or water. Use a single edge razor blade to score the glazing along the edge of the frame. Holding the razor blade at a 45 degree angle, scrape glazing from glass. Wipe remaining residue off with window cleaner or mineral spirits. Clean frame with a mild detergent and water, or use a TSP solution. Rinse well and allow to dry completely. Mask off glass. Prime door lite frames with an alkyd- or acrylic-based primer. Allow primer to dry before applying finish paint coats. Use high-quality acrylic latex house paint, following manufacturer's application instructions. Use exterior grade finishes for outside surfaces.

Classic Craft® and Fiber-Classic® Doors:

To Finish Doorlite Frames and Panel Inserts:

Remove any excess glazing sealant by first spraying with a window cleaner or water. Use a single edge razor blade to score the glazing along the edge of the frame. Holding the razor blade at a 45° angle, scrape glazing from glass. Wipe remaining residue off with window cleaner or mineral spirits. Mask off glass. Paint or stain using same materials as for the door. (See below).

To Paint Doors:

Clean first with mild detergent and water or use a TSP (tri-sodium phosphate) solution. Rinse well and allow to dry completely. Prime with an alkyd- or acrylic-based primer. Allow primer to dry completely, then paint with acrylic latex house paint, following paint manufacturer's application instructions. Use a primer and paint that are compatible. Use exterior grade finishes for outside surfaces. Paint edges and exposed ends of door.

To Stain Doors:

Clean first with a clean cloth and mineral spirits and allow to air dry or wash door with mild detergent and water, or a TSP (tri-sodium phosphate) solution. Rinse well and allow to dry completely. For stained surfaces, we **only** recommend the use of the stain and clear coat products found in the **Therma-Tru Same-Day Stain™ Finishing Kit**. Apply stain with a rag. The longer the stain is left to "setup" before wiping off, the darker the color will be. Using a clean rag, wipe off the stain to the color shade you desire. Remove any excess stain from the panel grooves with the foam brush provided; allow the stain to dry for at least 6 hours before applying topcoat. See **Therma-Tru Same-Day Stain™ Finishing Kit** instructions for complete details.

Therma-Tru Composite Door Frame Components:

To Paint Therma-Tru Composite Door Frame Components:

Clean first with mild detergent and water or use a TSP (tri-sodium phosphate) solution. Rinse well and allow to dry completely. Mask off hardware and remove weatherstripping before painting. Use high-quality acrylic latex house paint, following manufacturer's directions for application. Use exterior grade finishes for outside surfaces.

To Stain Therma-Tru Composite Door Frame Components:

Clean first with mild detergent and water or use a TSP (tri-sodium phosphate) solution. Rinse well and allow to dry completely. For stained surfaces, we **only** recommend the use of the stain and clear coat products found in the **Therma-Tru Same-Day Stain™ Finishing Kit**. Apply stain with a rag. The longer the stain is left to "setup" before wiping off, the darker the color will be. Using a clean rag, wipe off the stain to the color shade you desire. Allow the stain to dry for at least 6 hours before applying topcoat. See **Therma-Tru Same-Day Stain™ Finishing Kit** instructions for complete details.

For California Residents only

⚠️ **WARNING:** Cancer and Reproductive Harm
www.P65Warnings.ca.gov

©2016 Therma-Tru Corp. All rights reserved. THERMA-TRU and the Therma-Tru Logo are trademarks of Therma-Tru Corp. Registered trademarks are registered in the U.S. and may be registered internationally. Therma-Tru Corp. is an operating company of Fortune Brands Home & Security, Inc.

THERMA-TRU®
DOORS

Builder, Subcontractor or Supplier:

Please forward these instructions to the homeowner.

Therma-Tru® certified door systems and Therma-Tru® door systems that require product approval (typically for coastal applications) may require special assembly, components and installation. Always refer to the certified system requirements and product approval assembly and installation drawings on our website for these applications.

Building codes can vary by Jurisdiction, County and/or State. Always check for any specific assembly or installation that may be required by Code in your area.

Installation Instructions for Vented Sidelite Door Systems

These installation instructions are designed to assist door installers who have an understanding of carpentry principles, and know how to properly and safely use power tools. The purpose of these instructions is to illustrate how to install a Therma-Tru® door system using methods and materials that help eliminate air infiltration and water related leaks. If the directions are closely followed, the door system will have a long useful life with good resistance to air and water intrusion problems.

These methods are "tried and true" They are used widely by builders and remodelers who are serious about managing and keeping water outside the home. Rather than eliminate any steps that may be unclear to you, please call 1-800-THERMATRU and ask for clarification. If you remain unclear, please seek more professional assistance with the installation.

Required Tools & Materials: Tape measure, 6-foot and 2-foot level, framing square, at least 20 feet of string or twine and push pins, several tubes of high-quality hybrid polymer, elastomeric or polyurethane sealant (Therma-Tru recommends OSI QUAD MAX sealant for its adhesion strength and long-term durability across various building materials applications), caulking gun, step ladder, small pry bar, hammer, safety glasses, gloves, utility knife, punch or brad nailer, tin snips, electric drill or screw gun, two screw drivers (one Phillips and one flat-blade), composite or cedar shims, putty knives, one stiff, one flexible, exterior grade number 8 x 2-1/2" screws, self-adhesive flashing tape, j-roller, rigid head flashing, closed cell low expansion polyurethane window and door foam (Therma-Tru recommends OSI QUAD FOAM because it surpasses our requirements and is available with a professional application gun, allowing multiple uses from one can of foam), proper foam application gun, foam cleaner and a rigid Therma-Tru sill pan. Exterior trim if needed.

The door unit is large, heavy and can be cumbersome to lift, move and position. Use safe lifting techniques and a helper(s) to assist you with installation, in order to prevent personal injury and damage to the unit, and to help facilitate proper installation.

Read all instructions before starting.

Therma-Tru® Recommended Best Practices

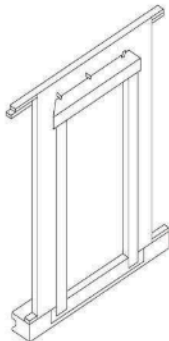

Use Water Resistant Barrier and Flexible Flashing: We recommend the use of a Water Resistant Barrier (WRB) applied to the exterior sheathing (OSB or other) and the use of an adhesive or flexible flashing product to seal around the opening. The WRB should be cut in the opening (follow manufacturer's guidelines) with the head of the flap taped up, to be sealed later in Step 13. The flashing should be applied in an overlapping manner as shown, always working from the bottom up (follow manufacturer's guidelines).

Use a Sill Pan: We recommend you first "dry fit" the sill pan in the opening, following the instructions furnished with the sill pan. Place the right and left sill pan ends tight against the sides of the opening. Check the center section for proper length and if necessary, cut with a hack saw or tin snips. Be sure to allow 2 inches of overlap at the joints.

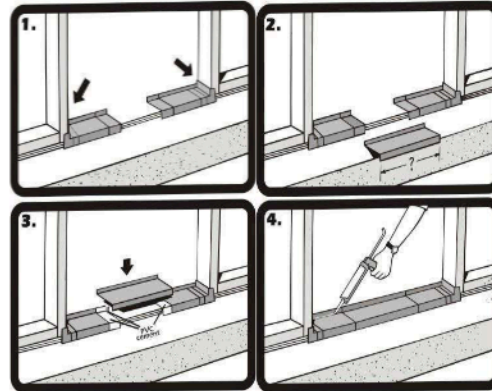

Note: Use only the PVC cement provided in the sill pan kit to glue the pieces together. The sill pan must be sealed to the sub-floor using a high-quality hybrid polymer, elastomeric or polyurethane sealant; Therma-Tru recommends OSI QUAD MAX, but do not apply sealant to the bottom of the sill when using a sill pan.

Step 1: Check Door Unit.



Check width and height.

Measure size of frame (width and height), not brickmould.

Remove cleats and packaging, but keep door fastened closed with transport clip. Do not remove the transport clip until instructed to do so later in Step 9.

Step 2: Check and Prepare Opening.

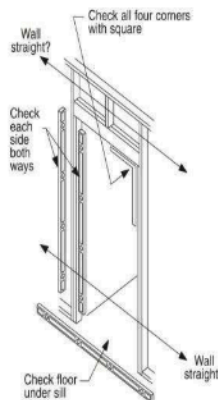

Is the opening the correct size for the door unit? Check it against the door frame size now, before installation. The opening should be frame height plus 1/2 inch, and frame width plus 1/2 inch to 3/4 inch. **Fix any problems now.**

Are the framing and walls **PLUMB**? Use a 6 foot level and check both sides of the opening, both ways (front to back and right to left). **Fix any problems now.**

Is the sub floor level and solid? **Provide a flat, level, clean weight bearing surface so the sill pan or sill can be properly caulked and sealed to the opening. Scrape sand or fill as required.**

Note: If additional floor covering clearance is required, attach the shim board to the sub floor. Be sure to caulk well under the shim board.

Is the opening square? Check all corners with a framing square. Double check by comparing diagonal measurements. **Fix any problems now.**

Pre-Hung Venting Unit Installation

Step 2 cont.: Check and Prepare Opening.

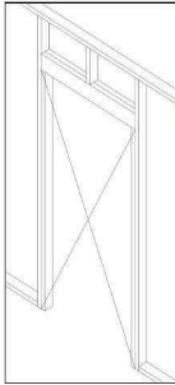

Check to be sure the framing walls around the opening are in the same plane. Do this by performing a "string test" for plumb.

String Test for Plumb: Attach a string diagonally across the opening from the outside, as shown. The string(s) should gently touch in the center, if not the opening is "out of plumb" by twice that distance and needs to be corrected. Flip the string over itself to check both planes. *Fix any problems now.*

*An "out of plumb" condition is one of the most common reasons door units leak air and water.

Step 3: Caulk the Sub Floor.

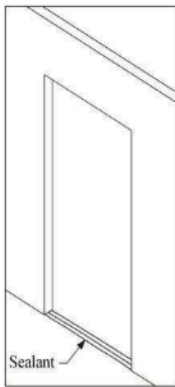

On the sub floor at opening, place 3 very large beads of sealant. Run beads full width of the opening.

Use **Only** a high-quality hybrid polymer, elastomeric or polyurethane sealant; Thermo-Tru recommends OSI QUAD MAX.

Use an Entire Tube when Caulking along the Sub Floor.

Step 3A: Installation with a Sill Pan.

Place the right and left sill pan ends onto the caulk beads and tightly against the side of the opening.

Then, liberally coat the overlapped areas and the recessed areas of the pieces with the PVC cement provided. Place center section(s) in position and hold pieces together long enough to ensure a good bond.

For added protection, spread a bead of caulk along the glue joints and to help prevent air infiltration, run a bead of caulk along the lower interior edge of the sill pan. Additional caulking could affect the performance of the sill pan.

Do Not Caulk the bottom of the Sill when using a sill Pan.

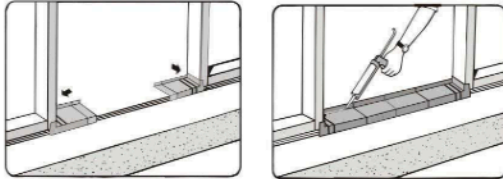

Step 3B: Installation without a Sill Pan.

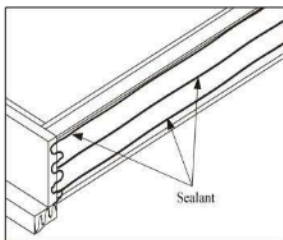

Lay the door unit on edge or face so that the bottom surface of the sill can be caulked. Place very large beads of caulk across the full width of the sill. Additionally, place beads of caulk along the junction of the sill and the jamb and on the bottom surface of the jambs and brickmould.

Note: If a sill extender is used, place a large bead of caulk at the junction of the extender and the sill approach.

Step 3C: Caulking Back side of Brickmould.

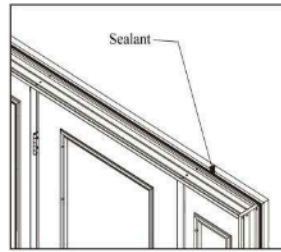

Important!

Apply sealant to the back side of brickmould around the entire perimeter of the door unit. A 1/2 - 5/8 inch bead of a high-quality hybrid polymer, elastomeric or polyurethane sealant is essential. Thermo-Tru recommends OSI QUAD MAX.

Step 4: Place Unit in Opening and Temporarily Fasten.



Lift the unit up. With top edge tilted away from opening, center the unit and place sill down onto sill pan or caulk beads and tilt into opening.

For all door unit configurations, note the hinge locations and mark those locations on the jamb faces near the door surfaces. Pre-drill 1/8 inch diameter holes at these locations for screw placement.

For Thermo-Tru Composite Door Frame systems, also pre-drill 1/8 inch diameter holes between hinge locations on both jambs.

A counter sink bit will help to conceal the screw heads, if not using provided hidden fastening system.

Install screws in the center pre-drilled hole locations on both jambs to temporarily secure the unit in the place. Do not drive screws completely in at this time. Use #8 X 2-1/2 inch or 3 inch exterior grade screws. If installing with provided hidden fastening system, install with provided screws.

Do Not Fasten through the Brickmould.

Step 5: Plumb and Fasten Hinge Side Mull Post.

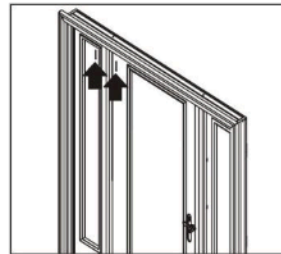

Use a 6 foot level and plumb the hinge side mullion both ways (right to left and inside to outside).

Pre-drill and insert a screw through the frame into the header, on each side of the hinge mull post. If installing with provided hidden fastening system, install with provided screws.

Do not drive the screw completely in at this time.



Shim directly over hinge side mull post. Using a 6 foot level, recheck hinge mull post to ensure it is plumb and straight. Finish driving screw tight.

Note: When installing a French door with active sidelites, first set the hinge mullion for the passive door. For details on properly setting the astragal slide bolt hole locations, follow the instructions in the astragal site pack.

Step 6: Adjust and Fasten Lock Side Mull Post.

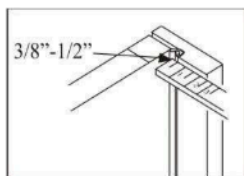

Adjust lock side mull post so that the weatherstrip contacts the door surface equally at the top, middle, and bottom, an even $3/8'' - 1/2''$ when fully closed. Pre-drill and insert a screw through the frame into the header, on each side of the lock mull post.

Do Not drive the screw completely in at this time.

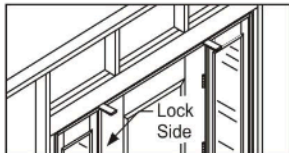

Shim directly over lock side mull post. Recheck lock mull post to ensure weatherstrip contact is even top to bottom. Finish driving screw tight.

Step 7: Adjust and Secure Side Jamb.

Adjust the sidelite hinge jamb on the hinge mull side of the unit to obtain even weatherstrip contact top to bottom at the lock side of the sidelite. Place a screw through the hinge side jamb, into the stud, at each remaining hinge location.

For Thermo-Tru Composite Door Frame systems, also place screws between hinge locations.

Do Not drive the screws completely in at this time.

Shim above the screws between the opening and the jamb and make adjustment so the margin between the sidelite and mullion are even top to bottom. This margin will be slightly larger than the margin at the door. Recheck sidelite hinge jamb to ensure weatherstrip contact is even top to bottom. Finish driving screws tight. Repeat the previous step on the sidelite hinge jamb on the lock mull side of the unit.

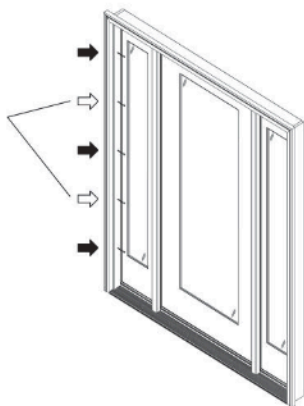

Step 8: (French Door) Temporary Shim at Head Jamb.

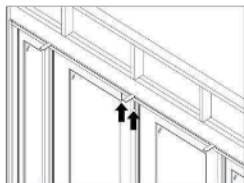

When installing a French door with active sidelites, place temporary shims above the center of the head frame, between the strike plate screws.

Pre-drill and insert long screws through the strike plate and into the header, then remove the temporary shims.

Step 9: Remove Transport Clip and Open Door.

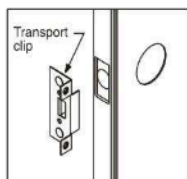

Remove transport clips. Confirm door and sidelites operate properly.

Make adjustments as needed.

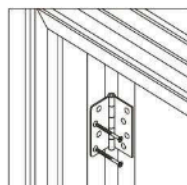

With sidelites open, drill $1/8''$ diameter pilot holes and install the long hinge screws in the hinge locations closest to the weatherstrip. Do this for all hinges.

Step 10: Adjust Sill.

Your door unit has adjustable threshold caps. When properly adjusted, it should be snug and slightly difficult to pull a dollar bill out from under the door and sidelites when fully closed. The dollar bill should be able to be removed without tearing.

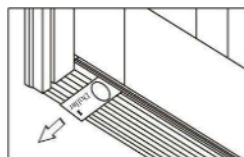

This check should be performed at each adjustment screw location on each active threshold cap.

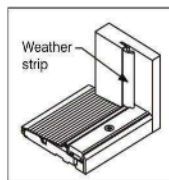

After adjusting the threshold cap, ensure that the weatherstrip is *flush* with the top of the threshold cap. Trim as necessary.

Step 11: Install Corner Seal Pads – Inswing units Only.

Apply sealant (a high-quality hybrid polymer, elastomeric or polyurethane sealant; Thermo-Tru recommends OSI QUAD MAX.) at the joint where the threshold cap meets the door jamb.

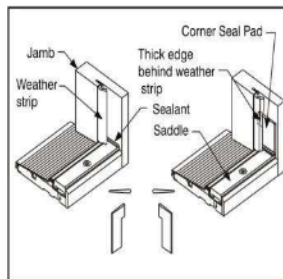

Remove the self-stick paper from the corner seal pads and apply to the jamb or mull post, with the *bottom* lined up evenly with the top of the threshold cap. When the pad is correctly installed, the tab is on top and the narrow part is on the bottom.

The bottom of the pad is the same width of the threshold cap to help with alignment during installation. Corner pads must be installed on

both sides of each active opening.

Pre-Hung Venting Unit Installation

Step 12: Weatherproof, Finish and Maintain.

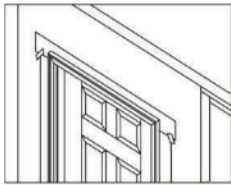

Provide and maintain a properly installed drip cap or head flashing to protect top of surfaces from **Water intrusion** and damage. Tape and properly seal the top flap of the Water Resistive Barrier (WRB) over the head flashing.

Caulk around **entire** "weather" side of unit, sealing along the brickmould to the flashing material or siding and seal all joints between the jambs and moldings.

Seal the joints between the exterior hardware trim and the door face to **prevent** air and water infiltration.

Place and set galvanized finish nails through the brickmould around the perimeter. Use exterior grade screws if you are installing a storm door to the brickmould. Countersink all fasteners and cover with exterior grade putty.

Use a low expansion window and door foam in the cavity between the opening and unit to reduce **air & water infiltration** and **heat transfer**. Therma-Tru recommends OSI QUAD FOAM.

All Therma-Tru® Fiberglass doors must be finished within 6 months of the installation date for continued warranty coverage.

Paint or stain according to Therma-Tru® Finishing instructions. Do Not paint or stain the weatherstrip, it is "friction-fit" and easily removed for painting or staining.

All 6 sides of the doors must be finished. All door edges must be inspected and maintained as regularly as all other surfaces.

All bare wood surfaces such as the door frame exposed to weather should be primed and painted or stained and top coated *within* two weeks of exposure for best performance.

Maintain or replace sealants and finishes as soon as any deterioration is evident. For semi-gloss or glossy paint or clear coats, do this when the surface becomes dull or rough. More severe climates and exposures will require more frequent maintenance.

Access our website www.thermatru.com for printable versions of the installation and Same-Day® Stain finishing instructions and to view our Troubleshooting video for minor installation issues and adjustments.

Finishing Instructions.

Work only when temperatures are between 50°and 90°F and with humidity less than 85%. Do not finish in direct sunlight. Work only in well-ventilated areas.

Smooth-Star® Doors:

To Paint Doors:

Clean first with mild detergent and water or use a TSP (trisodium phosphate) solution. Rinse well and allow to dry completely. Mask off hardware, glass and remove weatherstripping before painting. Use high quality acrylic latex house paint, following manufacturer's directions for application. Use exterior grade finishes for outside surfaces. Paint edges and exposed ends of door.

To Paint Doorlite Frames:

Remove any excess glass sealant by first spraying with a window cleaner or water. Use a single edge razor blade to score the sealant along the edge of the frame. Holding the razor blade at a 45 degree angle, scrape the sealant from glass. Wipe remaining residue off with window cleaner or mineral spirits. Clean glass frame with a mild detergent and water, or use a TSP solution. Rinse well and allow to dry completely. Mask off glass. Prime glass frames with an alkyd- or acrylic-based primer. Allow primer to dry before applying finish paint coats. Use high-quality acrylic latex house paint, following manufacturer's application instructions. Use exterior grade finishes for outside surfaces.

Fiber-Classic® Doors:

To Finish Doorlite Frames and Panel Inserts:

Remove any excess glass sealant by first spraying with a window cleaner or water. Use a single edge razor blade to score the sealant along the edge of the frame. Holding the razor blade at a 45° angle, scrape the sealant from glass. Wipe remaining residue off with window cleaner or mineral spirits. Clean glass frame with a mild detergent and water, or use a TSP solution. Rinse well and allow to dry completely. Mask off glass. Prime glass frames with an alkyd- or acrylic-based primer. Allow primer to dry before applying finish paint coats. Use high-quality acrylic latex house paint, following manufacturer's directions for application and dry time. Use exterior grade finishes for outside surfaces.

To Paint Doors:

Clean first with mild detergent and water or use a TSP (tri-sodium phosphate) solution. Rinse well and allow to dry completely. Prime with an alkyd- or acrylic-based primer. Allow primer to dry completely, then paint with acrylic latex house paint, following paint manufacturer's application instructions. Use a primer and paint that are compatible. Use exterior grade finishes for outside surfaces. Paint edges and exposed ends of door.

To Stain Doors:

Clean first with a clean cloth and mineral spirits and allow to air dry or wash door with mild detergent and water, or a TSP (tri-sodium phosphate) solution. Rinse well and allow to dry completely. For stained surfaces, we only recommend the use of the stain and clear coat products found in the **Therma-Tru® Same-Day® Stain Finishing Kit**. Apply stain with a rag. The longer the stain is left to "setup" before wiping off, the darker the color will be. Using a clean rag, wipe off the stain to the color shade you desire. Remove any excess stain from the panel grooves with the foam brush provided; allow the stain to dry for at least 6 hours before applying topcoat. See **Therma-Tru® Same-Day® Stain Finishing Kit** instructions for complete details.

Therma-Tru Composite Door Frame Components:

To paint Therma-Tru Composite Door Frame Components:

Clean first with mild detergent and water or use a TSP (tri-sodium phosphate) solution. Rinse well and allow to dry completely. Mask off hardware and remove weather-stripping before painting. Use high-quality acrylic latex house paint, following manufacturer's directions for application. Use exterior grade finishes for outside surfaces.

To Stain Therma-Tru Composite Door Frame Components:

Clean first with mild detergent and water or use a TSP (tri-sodium phosphate) solution. Rinse well and allow to dry completely. For stained surfaces, we only recommend the use of the stain and clear coat products found in the **Therma-Tru Same-Day Stain™ Finishing Kit**. Apply stain with a rag. The longer the stain is left to "setup" before wiping off, the darker the color will be. Using a clean rag, wipe off the stain to the color shade you desire. Allow the stain to dry for at least 6 hours before applying topcoat. See **Therma-Tru Same-Day Stain™ Finishing Kit** instructions for complete details.

Pre-hung Arch/Radius Installation Instructions

1 CHECK AND PREPARE OPENING

- Is subfloor level and solid? Provide a flat, level clean bearing surface so the sill may be caulked and sealed to the opening. Scrape, sand, or fill as required.
- Shim subfloor for floor covering clearance if required. If shimming, caulk under shims.
- Is opening square? Check all corners with a framing square. Double-check by comparing diagonal measurements. Fix any problems now.
- Are framing and walls plumb? Use a 6-foot level and check both sides of opening, both ways. Fix any problems now.
- Are the wall surfaces around the opening on the same plane? There must be no "warps" or "jogs". Fix any problems now.
- Is opening correct size? Check it against door frame size now before installation. Opening should be frame height plus $\frac{1}{2}$ " and frame width plus $\frac{1}{2}$ " to 1".

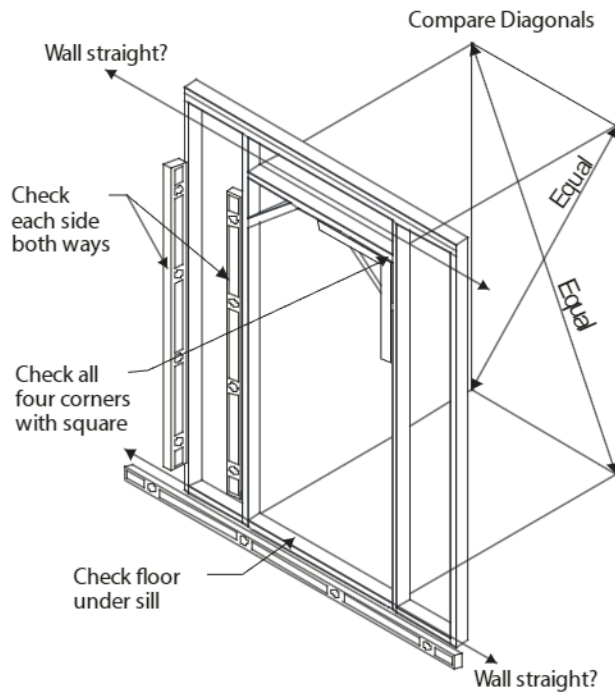

2 SUPPORT FRAME CONSTRUCTION

Build support framing at top for radius/arched top head jamb as shown below

Radius Top Head Jamb

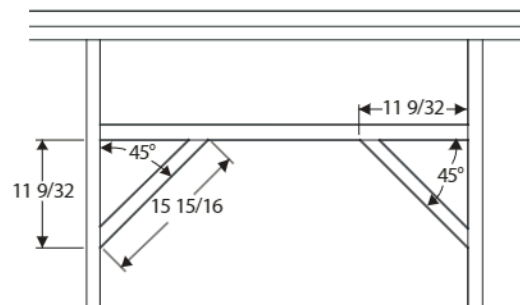

Arch Top Head Jamb

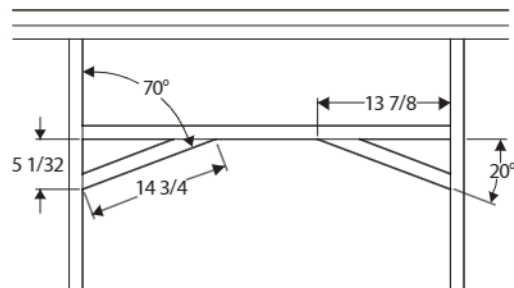

Common Arch Head Jamb

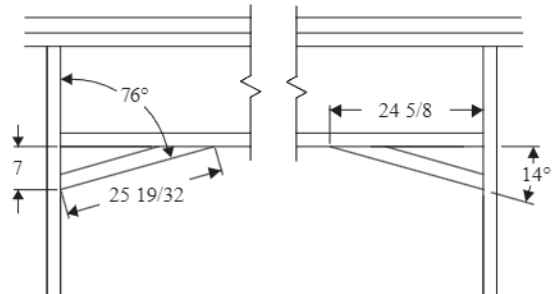

Refer to MSDRIST65 for all other Pre-Hanging Instructions

Pre-hung Arch/Radius Installation Instructions

3 SHIM BEHIND JAMBS, THEN ADJUST THE REST OF THE FRAME

- Go through another opening to work on swing side of door
- Leave door fastened closed with transport clip
- Shim at the indicated areas in the figure; Shim behind each hinge, shim at the angled framing members at the top, and shim side areas as shown
- Recheck hinge jamb with a 6-foot level to ensure it is plumb and straight
- Adjust frame so the frame face is flush with door face all around
- Secure hinge jamb from the other side of the door. Set nails or finish driving screws directly below shims
- Due to varying dimensions of mouldings, there may be a gap at the miter of the brick moulding where the radius/arch piece of the head meets the straight leg of the side. This is expected and should be caulked prior to painting.

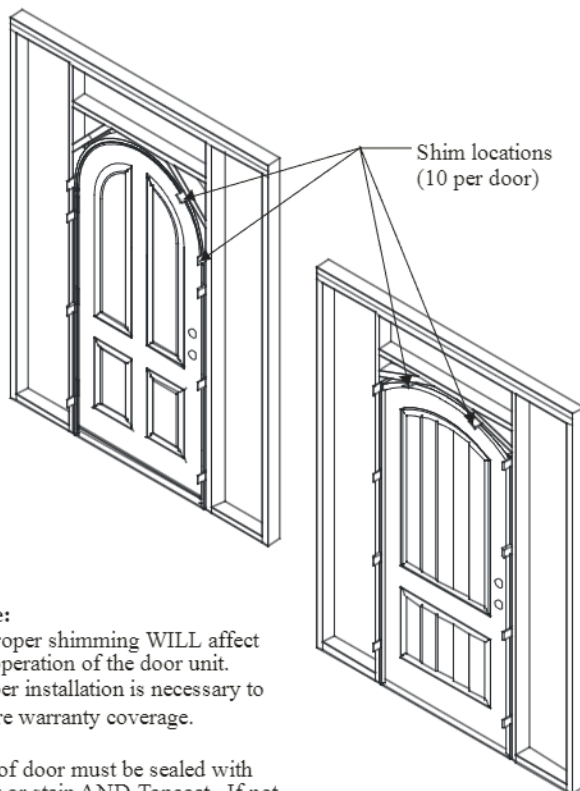

Note:
Improper shimming WILL affect the operation of the door unit. Proper installation is necessary to insure warranty coverage.

Top of door must be sealed with paint or stain AND Topcoat. If not finished the door warranty is VOID!

4 SCREW INSTALLATION

Special Instructions For Radius Top Head Jambs:

- Use #10 x 2" wood screws
- Install screws in the order shown below.
- Shims are required at all screw locations to control the final shape of the radius and to allow for the correct margins around the door.

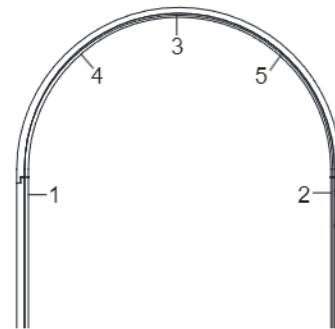

For Both Radius Top Head Jambs:

- Use #10 x 2" wood screws
- Position all screws in the location shown below. The screws must be positioned such that the weather-strip hides the screw heads.

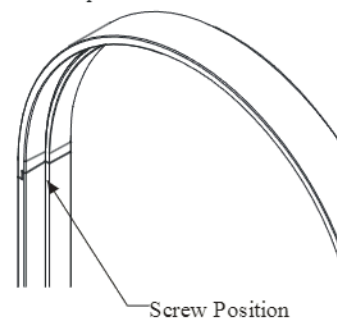

For California Residents only

WARNING: Cancer and Reproductive Harm
www.P65Warnings.ca.gov

Refer to MSDRIST65 for all other Pre-Hanging Instructions

Part#: MSDRARRADIST65 REV. D 8/18/2021

© Copyright 2011 Therma-Tru Corporation.
Therma-Tru Doors is an operating company of Fortune Brands